

SYSTEM energy

ESK 163L 250 Watt

Technical Specifications

Component:	3 way system	
Size	EV 165L woofer	165 mm (6 ^{11/2})
	EM 100 midrange	100 mm (4")
	ET 20 tweeter	20 mm (3/4")
Power Handling (Watt)	peak	250
	continuous program	125
Impedance	Ohm	4
Frequency response	Hz	50 - 23k
Sensitivity	dB/SPL	92
Outer diameter	mm	165
Mounting hole diameter	mm	145
Magnet size	mm	85
Total depth	mm	72
Mounting depth	mm	66
Weight of one component	Kg	0,920



ET 20

- 1 Tetolon dome; extremely light and well damped for a smooth and extended high frequency response.
- 2 20mm Ø, ultra light ferrofluid-cooled mobile voice coil.
- 3 High energy REN neodymium magnet.
- 4 Low carbon content plates for maximum magnetic permeability and high heat dissipation.
- 5 Damping material; controlling acoustic resonances insuring clear, brilliant high frequency tones.
- 6 High frequency diffraction lens, optimizing off-axis high frequency response.

EV 165L

- 1 Low carbon content plates for maximum magnetic permeability and high heat dissipation.
- 2 Large motor assembly provides excellent, voice coil control.
- 3 Pure copper long throw voice coil wound on Til former, for very good thermal and mechanical capacity.
- 4 Vent hole provides linear excursion and better thermal dissipation.
- 5 Water-repellent non-pressed paper cone provides deep, tight and dynamic bass output.
- 6 "V" cone, for the best off-axis response, clear mid-high frequency detail and powerful bass.
- 7 Rubber magnet cover provides damping to the basket and motor structure and protects from abrasions and damages.
- 8 DIN size basket coated with scratch-proof, corrosive-resistant material.
- 9 High density rubber surround, glued with heat-resistant adhesive.
- 10 Epoxy glue for basket and motor system provides perfect coupling.
- 11 Curve memory Nomex spider for consistent, reliable performance.
- 12 Tin-plated, high current terminals.
- 13 Silver-plated lead wires for maximum reliability and conductivity.

EM 100

- 1 Low carbon content plates for maximum magnetic permeability and high heat dissipation.
- 2 REN Neodymium magnet and central T-Pole, for a perfectly symmetrical field; maximum energy using minimum space.
- 3 Pure copper voice coil wound on Til former, for very good thermal and mechanical capacity.
- 4 Pure copper covered pole piece, for linear impedance and the best acoustic performance for mid-high frequencies.
- 5 Water-repellent treated paper cone.
- 6 "V" cone, for the best off-axis response and clear mid-high frequency detail.
- 7 DIN size basket coated with scratch-proof, corrosive-resistant material.
- 8 Tin-plated, high current terminals.
- 9 Silver-plated lead wires for maximum reliability and conductivity.
- 10 Flat foam surround, for linear mid frequency response and larger radiating surface.
- 11 Epoxy glue for basket and motor system provides perfect coupling.
- 12 Curve memory Nomex spider for consistent, reliable performance.

*Grilles included

CX 300

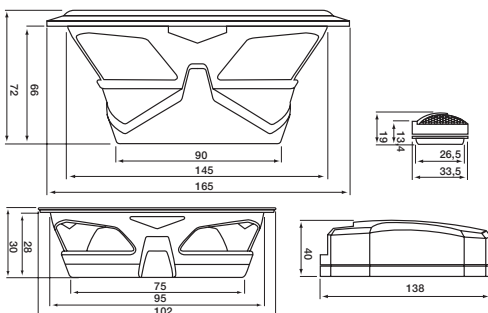
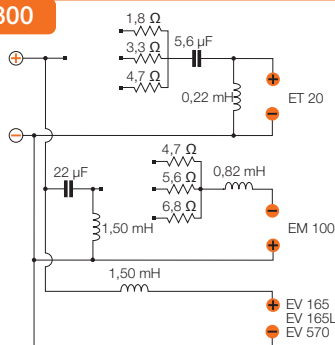

energy

New ENERGY: Raw power, refined style

ENERGY loudspeakers are the result of the HERTZ team's long experience and continuous research into automobile acoustics, as well as the deep knowledge of installation procedures. Their advanced engineering has been successfully combined with refined cosmetics to match with their high efficiency, stunning dynamics and musical accuracy. The 18 different components are the perfect way to ensure effortless reproduction in the most demanding situations. Add a powerful amplifier; the excellent timbre and high power handling make ENERGY the ideal choice for every system.

COMP

ENERGY woofers ensure excellent acoustic quality, thanks to a powerful and symmetrical motor structure and to the pressed paper "V" cone. The DIN size basket and the compact size make it easy to install in almost every factory OEM location. With the EV 165L, the long throw voice coil design and water repellent non-pressed paper cone provide deep, tight bass output.



ULTRA flat

EM 100 midrange: with its small size and shallow depth it can be installed in locations that would have been deemed impossible until now. The perfect addition ensuring excellent acoustic quality in challenging locations.



Compact SIZE

ET 20 is a revolutionary tweeter with Tetolon dome; its unique design was conceived to ensure state-of-the-art performance in the smallest space. The provided mounting hardware allows easy installation in the most challenging locations.



CX 200 and **CX 300** ENERGY system crossovers feature an aggressive, cosmetically appealing housing which protects the efficient, refined network: easy installation, reference acoustical performance in the mobile environment and the utmost reliability.



COAX

ECX ENERGY COAX feature the world renowned Tetolon dome tweeter with built-in crossover. Off-axis response can be controlled with the proprietary RHFC™ technology. ECX 87 has an excellent dome-cone tweeter with built-in crossover. In addition to this, ECX 690 has a Mylar supertweeter to ensure the best possible efficiency and high frequency extension. No other coaxial components can ensure the outstanding sound linearity, off-axis response and timbre quality of ENERGY loudspeakers.



SUB

ENERGY ES subwoofers were designed to work best when used in small enclosures. However, their electro-acoustic parameters are optimised for use in many different enclosure types; both in terms of typology (sealed box, reflex, bandpass, etc.) and in size, ensuring extraordinary versatility and performance. The use of a long excursion mobile voice coil and a high flux density double magnet have created subwoofers that can stand very high power with outstanding musicality and bursting dynamics. The special finish and butyl rubber rings offer protection along with an aggressive look.



Refined style